

OpenSource with Market Ready Enclosure

Bluetooth 5 to WiFi Gateway (BWG) provides connection from Bluetooth devices to cloud server. They are in market ready enclosure and pre-certified. OpenSource codes are available to expedite your application firmware and software development.

Gateway for Home/Small Mesh

BWG832F is a low cost Bluetooth 5-WiFi gateway for point to point or small mesh network where security is not required or limited decryption and authentication can be implemented in firmware.

BWG832X to Penetrate Multiple Walls

Using BT832X with +20 dBm max. TX, BWG832X can penetrate multiple walls or be used in wide area Bluetooth mesh applications.

BWG840F Secure BLE 5, 802.15.4 Gateway

Secure connection can be established using BT840F and ESP32. In addition to BLE 5, BT840F supports Thread and Zigbee protocols.

BWG840XE Secure, Longest Range Gateway

Using BT840X with +21.0 dBm max TX and available CODED PHY, BWG840X is the longest range gateway supporting BLE, Thread and Zigbee protocols

Nordic nRF52 Development Environment

Nordic nRF52 SoC in Bluetooth module communicates with a cloud server in message layers. Nordic nRF52 development environment should be used. Source codes specific to gateway interfacing with Fanstel BLE 5 sensors are available at:

<http://www.fanstel.com/download-opensource/>

Over-The-Air DFU

The Bluetooth module is supported by an Over-The-Air Device Firmware Upgrade (OTA DFU) feature. This allows for in the field updates of application software and SoftDevice.

WiFi Module Development-Mongoose OS

Development Kit (e.g., DK-BWG832F) is required to load codes into WiFi module. DK is preloaded with codes for connection to Fanstel development server.

Mongoose OS OpenSource codes for connecting to Fanstel development server and to **Google Cloud IoT Core** are available. They can be used as base to develop interface with other servers.

Link to download additional document and source codes:

<http://www.fanstel.com/download-opensource/>

Miscellaneous

- Size: 60x60x22mm
- Desk and wall mountable
- Power supply and USB cable included
- 2 LED indicators defined by user

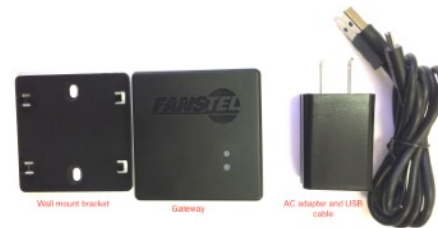

Gateway Summaries

Gateway	BWG832F	BWG832X	BWG840F	BWG840XE
WiFi module	ESP 8266	ESP 8266	ESP 32	ESP 32
BLE module	BT832F	BT832X	BT840F	BT840XE
Max module range	760 M at 1Mbps	1170 M at 1Mbps	2300M at 125 kbps	>4500M at 125 Kbps
FCC ID	X8WBT832	X8WBT832X	X8WBT840F	X8WBT840X
ISED	4100A_BT832	4100A-BT832X	4100A-BT840F	4100A-BT840X
CE			Compliant	Compliant
RCM			Compliant	Compliant
TELEC			201-190710/00	
QDID		97989	97989	108621
Development Kit	DK-BWG832F	DK-BWG832X	PK-BWG840XE	PK-BWG840XE

Table Of Contents

1. Introduction.....	3
BWG832F	3
BWG832X, BWG832XE	3
BWG840F, BWG840E	3
BWG840X, BWG840XE	3
Hardware and Accessories Required for Firmware Development.....	3
2. Gateway and Development Kit.....	5
Development Kit (DK).....	5
Gateway Development Kit Block Diagram.....	5
Gateway	7
Gateway Block Diagram	7
Testing Connection to Fanstel Mosquito Server	9
3. Develop Codes for WiFi Module ESP8266	12
Fanstel Mosquito Development Server	12
Google Cloud IoT Core.....	12
Preparing Gateway Board for Programming	13
Loading Firmware into WiFi Module	14
Connecting to Fanstel Mosquito Server	16
Connecting to Google Cloud Platform IoT Core	17
Programming WiFi Module in Production Gateway.....	19
4. Develop Codes for Bluetooth Modules.....	20
Nordic Development Environment.....	20
Fanstel Sensors.....	20
Interfacing with a Fanstel Evaluation Board	21
Check COM Port Connection	22
Starting Nordic nRF Connect.....	23
Over-The-Air DFU	24
Control Skyworks Power Amplifier in BT832X/XE	24
Control Skyworks Power Amplifier in BT840X/XE	27
Programming Bluetooth Module in Production Gateway.....	30
5. Gateway Schematics.....	31
BWG832F/X Schematics	31
BWG840F/X Schematics.....	32
6. Wall Mounting.....	33
Revision History	34
Contact Us	35

BWG832FX, BWG840F/X Bluetooth 5 to WiFi Gateway

1. Introduction

Bluetooth 5 to WiFi Gateway (BWG) provides connection from Bluetooth devices to cloud server. They are in market ready enclosure and pre-certified. OpenSource codes are available to expedite your application firmware and software development.

In BWG832F/BWG832X gateway, an ESP8266 WiFi module provides connection to cloud server. A Nordic nRF52832 module works as a Relay/Proxy node in a Bluetooth mesh, relaying message between a cloud server and other nodes in mesh network.

In BWG840F/BWG840X gateway, an ESP32 WiFi module can provide secure connection to cloud server. A Nordic nRF52840 module works as a Relay/Proxy node in a Bluetooth mesh, relaying message between a cloud server and other nodes in mesh network securely.

BWG832F

- ESP8266 WiFi module
- BT832F with Nordic nRF52832 SoC
- An AC adapter with USB cable
- Certifications: FCC, ISED

BWG832X, BWG832XE

- ESP 8266 WiFi module
- BWG832X: BT832X with Nordic nRF52832 SoC and SKY66112 power amplifier
- BWG832XE: BT832XE with Nordic nRF52832 SoC, SKY66112 power amplifier, an external antenna. Made to order only, no stock.
- An AC adapter with USB cable
- Certifications: FCC, ISED

BWG840F, BWG840E

- ESP32 WiFi module
- BWG840F: BT840F with Nordic nRF52840 SoC, supports BLE 5, 802.15.4
- BWG840E: BT840E with Nordic nRF52840 SoC, supports BLE 5, 802.15.4, external antenna. Made to order only, no stock
- AC adapter with USB cable
- Certifications: FCC, ISED, CE, RCM,TELEC

BWG840X, BWG840XE

- ESP32 WiFi module
- BWG840X: BT840X with Nordic nRF52840 SoC and SKY66112 power amplifier.Made to order only, no stock.
- BWG840XE: BT840XE with Nordic nRF52840 SoC, SKY66112 power amplifier, external antenna.
- An AC adapter with USB cable
- Certifications: FCC, ISED, CE, RCM

Hardware and Accessories Required for Firmware Development

The following are required to develop firmware for gateway WiFi and Bluetooth modules.

- Development Kit version of gateway. It contains accessories required to load WiFi firmware.

BWG832FX, BWG840F/X Bluetooth 5 to WiFi Gateway

Ver 1.01 Nov. 2021

- A Nordic nRF52DK for BWG832F/X/XE. Or, a Nordic nRF52840-DK for all Bluetooth modules.
- A TAG Connect cable to load firmware into gateway Bluetooth module.

BWG832FX, BWG840F/X Bluetooth 5 to WiFi Gateway

2. Gateway and Development Kit

Development Kit (DK)

A Development Kit, for example, DK-BWG832F is required to load firmware into WiFi module. A DK consists of the followings:

- A gateway with optional magnet
- A wall mount bracket. Don't install wall mount bracket for magnetic mounting
- An USB cable assemble including a cable and an USB to UART bridge board.
- An AC adapter with USB cable
- 10-pin flat cable for connection to Nordic nRF52DK or nRF52840DK.

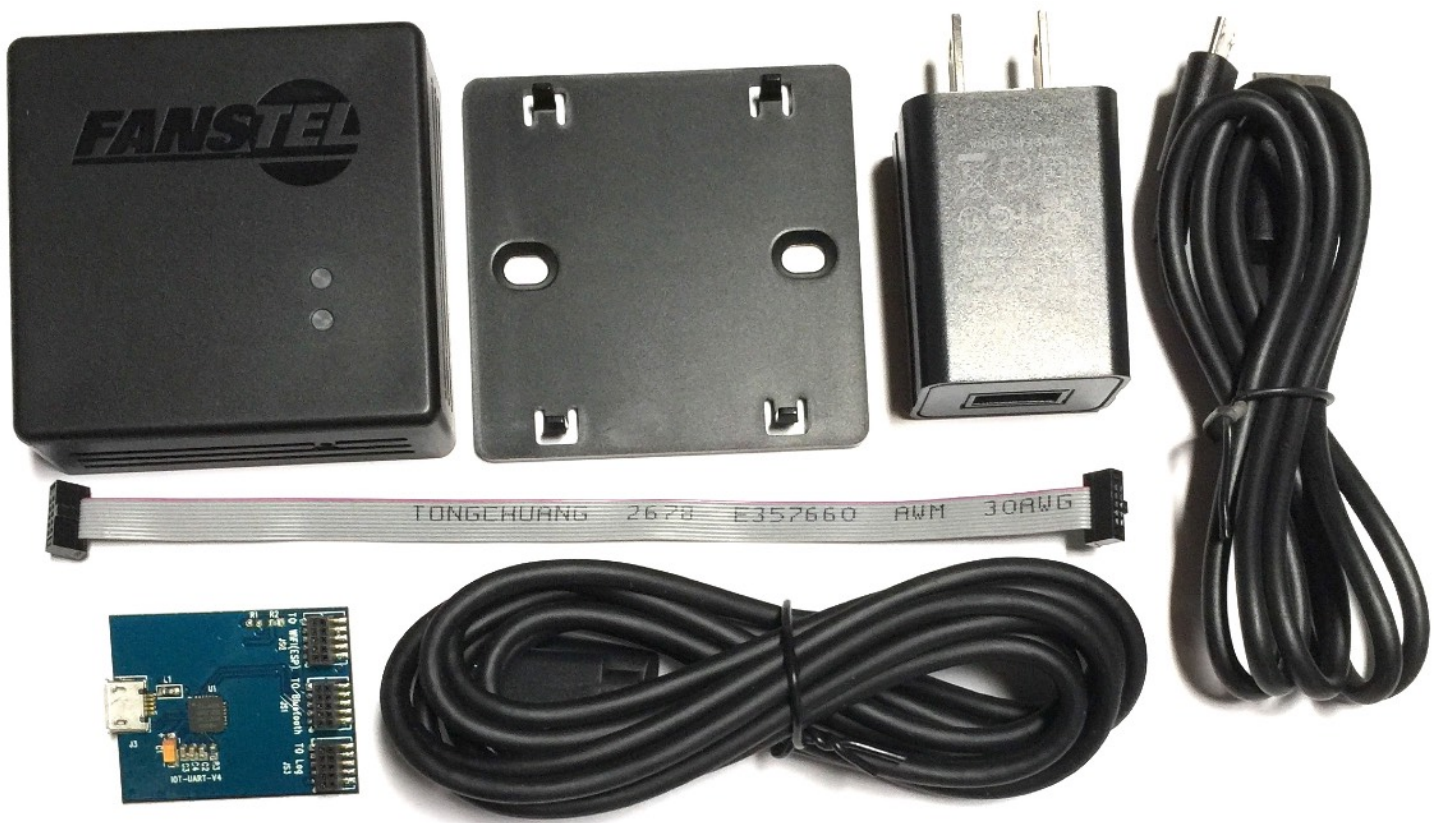

Gateway Development Kit Block Diagram

A gateway development kit has the following main components:

- A Fanstel Bluetooth 5 module
- An ESP8266 or ESP32 WiFi module
- Connect BLE-WiFi block allowing connection between (a) a PC and WiFi module (b) a PC and Bluetooth module (c) WiFi module and Bluetooth module.
- A micro USB connector for DC power input

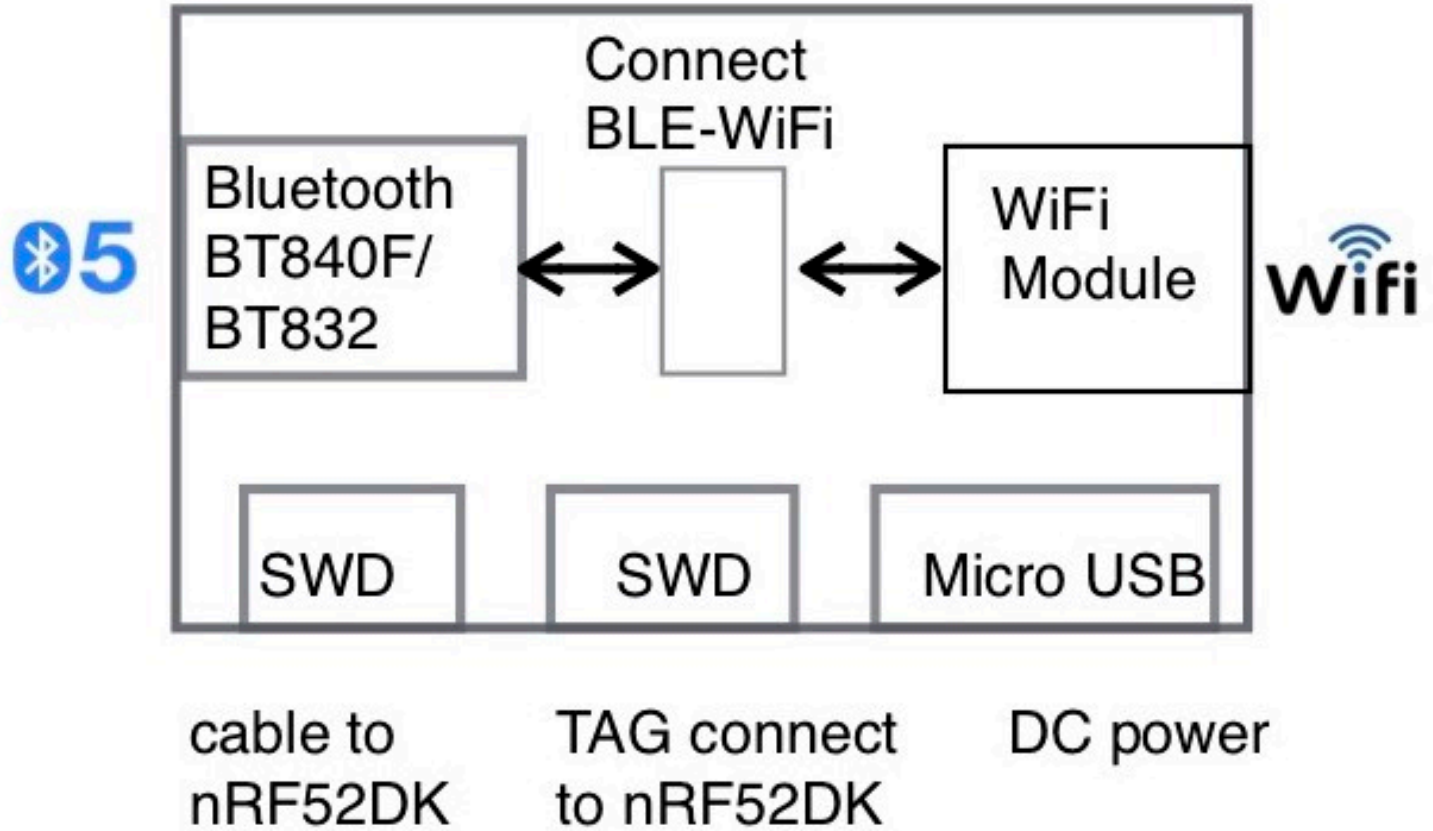

- A 10-pin flat cable connector to connect to a Nordic nRF52DK/nRF52840DK for loading firmware into Bluetooth 5 module.
- A 10-pin pad for TAG connect cable TC2050-IDC-NL-050-ALL to connect to a Nordic nRF52DK or nRF52840 DK for loading firmware into Bluetooth 5 module.

Gateway

A gateway package consists of the followings:

- A gateway
- A wall mount bracket.

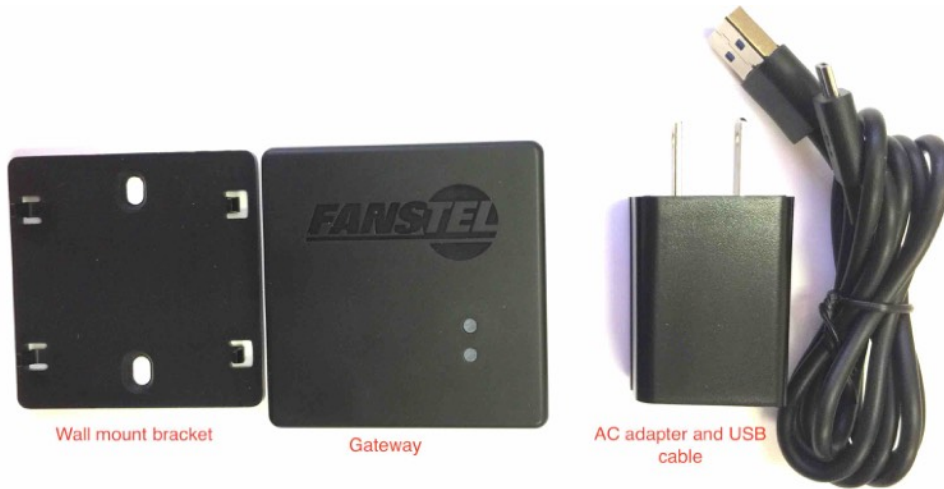

- An AC adapter with USB cable

Gateway Block Diagram

A gateway has the following main components:

- A Fanstel Bluetooth 5 module
- An ESP8266 or an ESP32 WiFi module

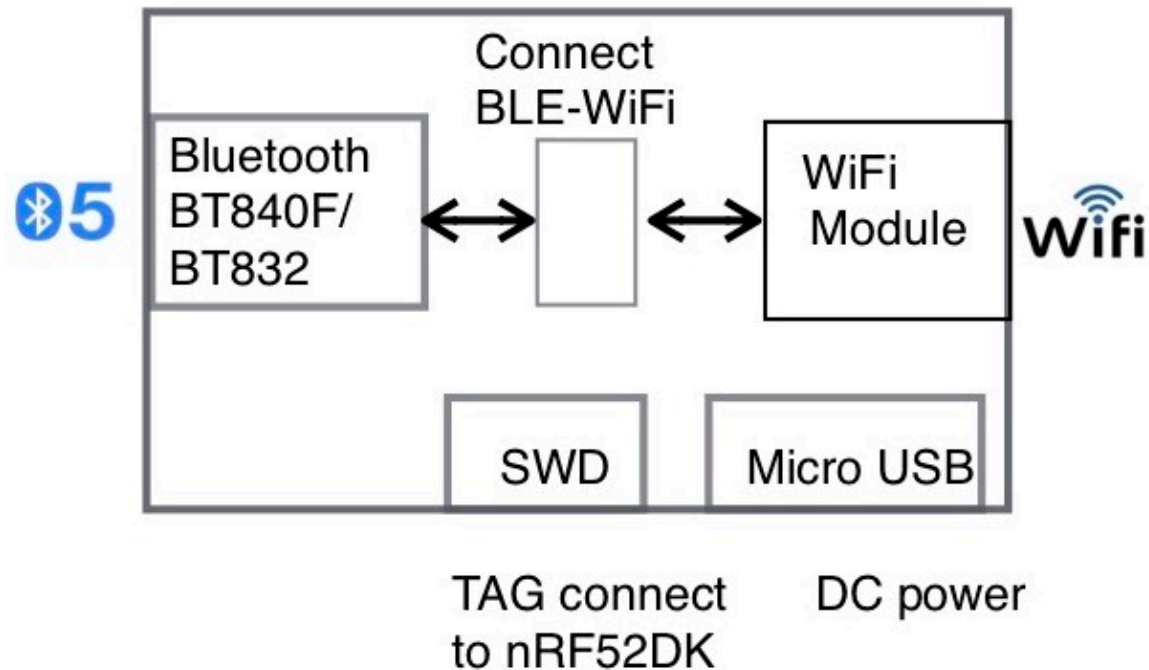

- Connect BLE-WiFi block allowing connection between (a) a PC and WiFi module (b) a PC and Bluetooth module (c) WiFi module and Bluetooth module. (The USB cable assemble included in DK is required for PC connection).
- A micro USB connector for DC power input
- A 10-pin pad for TAG connect cable TC2050-IDC-NL-050-ALL to connect to a Nordic nRF52DK for loading firmware into Bluetooth 5 module.

Testing Connection to Fanstel Mosquito Server

1. Set WiFi module to Access Point (AP) mode. .
 - Use tip of a paper clip to press and hold SW1 when connecting USB power supply to boot up.
2. Use a smartphone to connect to WiFi AP FanstelGW_XXXXXX
The XXXXXX is the device ID, 7A561D in the example. Please remember this ID.

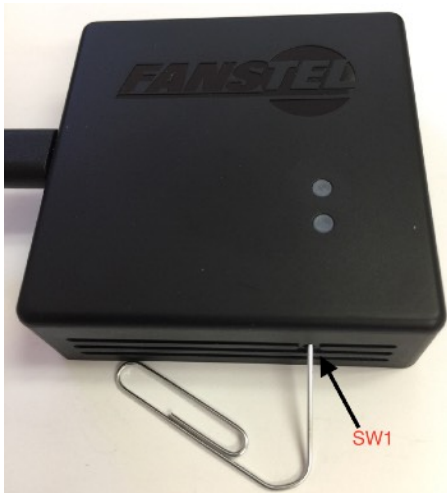

3. Open the web browser then go to 192.168.4.1
Enter your router information at the web page.

4. The Nordic and ESP chip's LED will flash when power up. The baudrate is set to 115200.
You should see the detail from log.

```
esp_mgos_init2      Mqtt_Demo 1.0 (20180321-071019/???)<LF>
esp_mgos_init2      Mongoose OS 2018032107 (20180321-071018/???)<LF>
esp_mgos_init2      CPU: ESP8266EX, 160 MHz, RAM: 52000 total, 46896 free<LF>
esp_mgos_init2      SDK 2.2.0-dev(e6d3ebb); flash: 4M<LF>
esp_print_reset_info Reset cause: 0 (power on)<LF>
mgos_vfs_dev_open   sysflash () -> 0x3fff08f4<LF>
mgos_vfs_mount      Mount SPIFFS @ / (dev 0x3fff08f4, opts {"addr": 32768, "size": 262144}
<LF>
mgos_vfs_mount      /: size 233681, used: 149345, free: 84336<LF>
mgos_sys_config_init MAC: 2E3AE818173F<LF>
mgos_sys_config_init WDT: 30 seconds<LF>
mgos_mdns_init      Listening on udp://:5353<LF>
mgos_mdns_hal_join_g Joining multicast group 224.0.0.251<LF>
bcn 0<LF>
del if1<LF>
del if0<LF>
us1<LF>
mode : null<LF>
mgos_wifi_setup     WiFi mode: off<LF>
mgos_http_server_ini HTTP server started on [80]<LF>
mgos_ota_shadow_init OTA over shadow initialised<LF>
mgos_ota_http_client Init done, ota_lib=(null), ota handler 1<LF>
mg_rpc_channel_mqtt 0x3fff022c esp8266_18173F/rpc/#<LF>
mg_rpc_channel_uart 0x3fff1524 UART0<LF>
mgos_init           Init done, RAM: 52000 total, 42156 free, 40016 min free<LF>
mgos_aws_shadow_init MQTT is not configured for AWS, not initialising shadow<LF>
mongoose_poll       New heap free LWM: 28184<LF>
```

5. Install the Android APP and input the ID.
6. Now the connection is made between the gateway and phone.

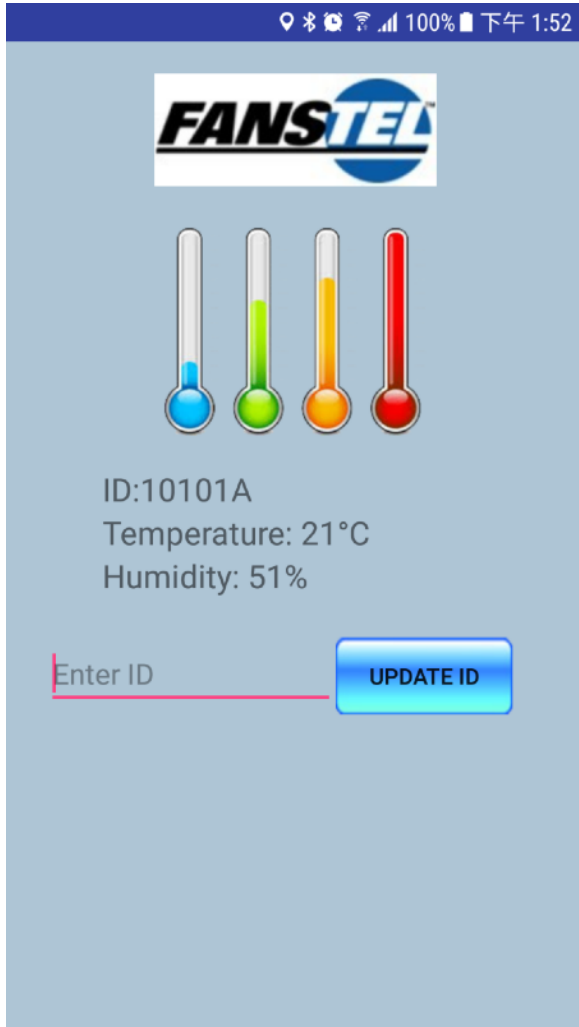

3. Develop Codes for WiFi Module ESP8266

Your first development gateway must be a Development Kit (DK). DK includes all accessories for WiFi interface development. For Bluetooth interface development, a Nordic nRF52DK is required, in addition.

All DK gateways are preloaded with firmware for connecting to a Fanstel server. Please follow procedures in the previous section to test connection to the Fanstel server before developing and loading your codes into gateway.

WiFi module is used to set up and maintain connection to a cloud server through a WiFi router.

Mongoose OS OpenSource codes for connecting to **Fanstel Mosquitto development server** and to **Google Cloud Platform IoT Core** are available. They can be used as base to develop interface with other servers. Link to download additional document, hex, and source codes:

<http://www.fanstel.com/download-open-source/>

MQTT (MQ Telemetry Transport), was also known as Message Queuing Telemetry Transport) protocols are used to interface with cloud server.

Fanstel Mosquitto Development Server

WiFi modules in DK is preloaded with firmware connecting to Fanstel development server. Fanstel team can better assist developers on trouble-shooting interface issues in the early days of development.

Upon successfully test your codes with Fanstel development server, please use other servers instead.

Google Cloud IoT Core

A block diagram for interfacing ESP 8266 with Google Cloud IoT Core is shown.

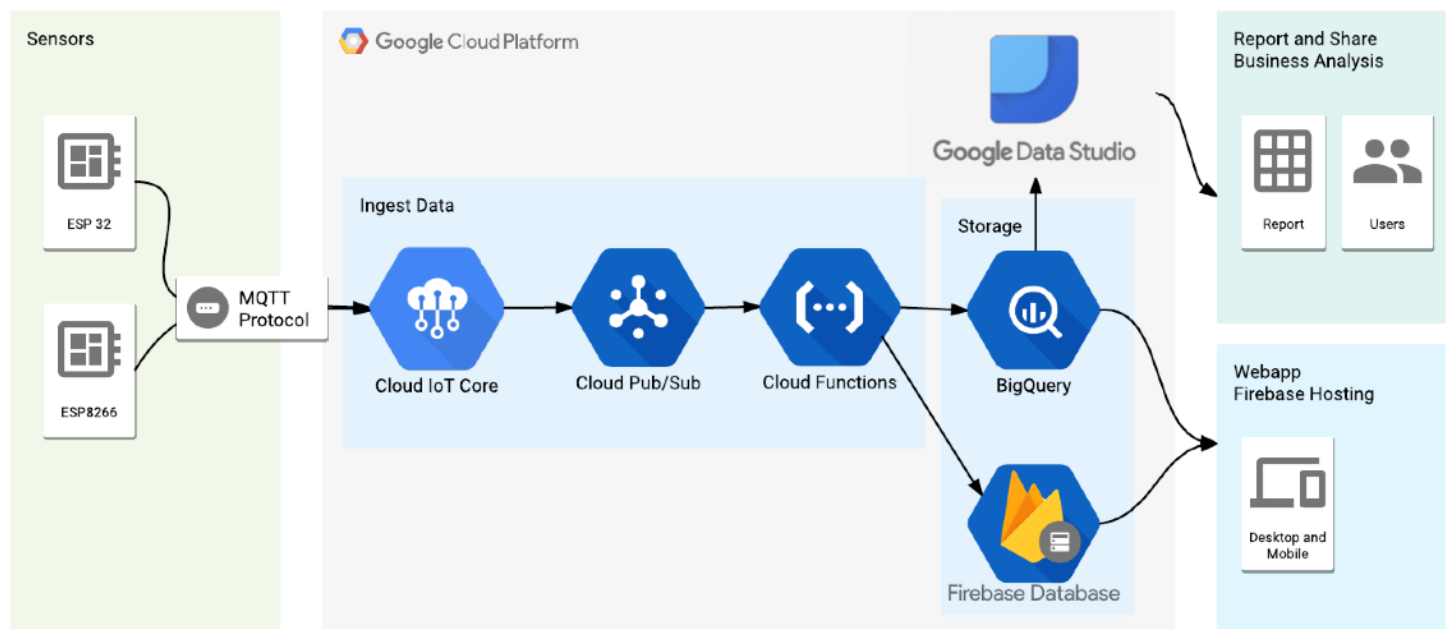

Preparing Gateway Board for Programming

A. Remove 4 screws from bottom side of enclosure and remove gateway board from enclosure.

The small PCBA IoT-JS7 is for connecting WiFi module UART port to Bluetooth module UART port. Remove it from gateway board..

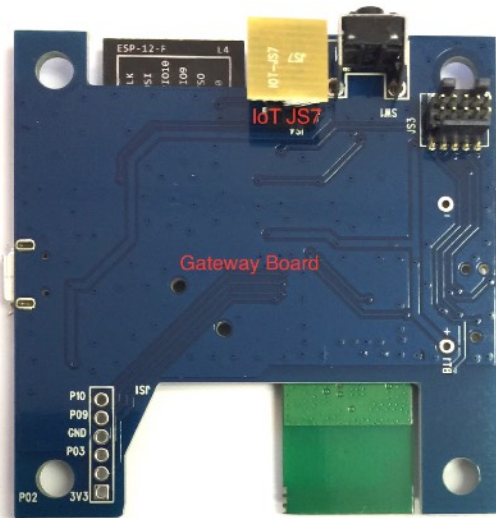

B. USB to UART bridge board has 3 female connectors. Connect to

- TO WiFi (ESP), JS2: for connecting WiFi module to a PC USB port
- TO Bluetooth, JS1: for connecting Bluetooth module to a PC USB port.
- TO log, JS3.

Connect the USB-UART Bridge Board JS2 to Gateway Board JS4. Switch SW1 can be used to set boot mode of WiFi module.

- Set SW1 to **ON** for **UART-Boot mode**, or loading firmware from a PC to WiFi module during booting up.
- Set SW1 to **OFF** for **Flash-Boot mode**, or booting up from flash memory in normal operation.

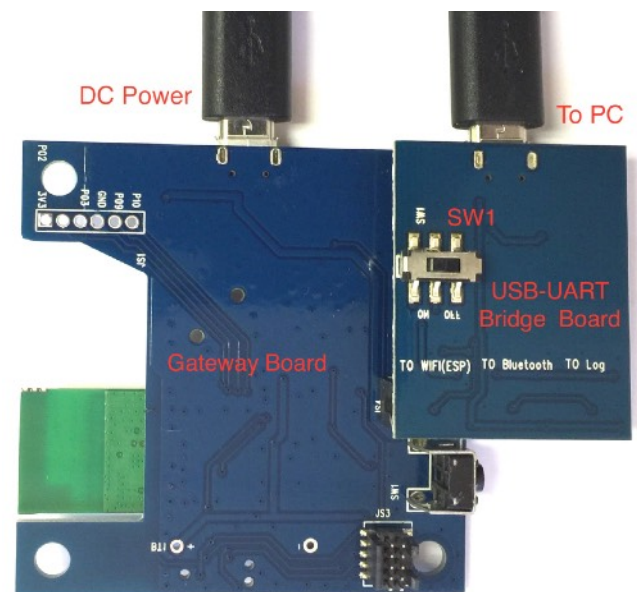

BWG832FX, BWG840F/X Bluetooth 5 to WiFi Gateway

Loading Firmware into WiFi Module

- Copy the mos.exe and build in the same folder.
- Connect USB-UART Bridge Board to a PC with an USB cable.
- In the Window command mode
Type command: mos flash --port COM5
The COM port number can be different in your computer.
- If everything is good.
It will show "All done!".

```
Running flasher @ 460800...
Flasher is running
Flash size: 4194304, params: 0x0240 (dio,32m,40m)
Deduping...
 2736 @ 0x0 -> 0
262144 @ 0x8000 -> 28672
778528 @ 0x100000 -> 0
  128 @ 0x3fc000 -> 0
Writing...
 4096 @ 0x7000
 8192 @ 0x1e000
20480 @ 0x2c000
 4096 @ 0x3fb000
Wrote 36864 bytes in 0.44 seconds (657.53 KBit/sec)
Verifying...
 2736 @ 0x0
 4096 @ 0x7000
262144 @ 0x8000
778528 @ 0x100000
 4096 @ 0x3fb000
  128 @ 0x3fc000
Booting firmware...
All done!
```

11. Remove the USB-UART Bridge Board from Gateway Board.

- Re-install the small IoT-JS7 board to JS4 of Gateway board. IoT -JS7 board is symmetrical. It can be installed in either direction.
- Hold the Gateway Board SW1 button when connecting USB power supply to boot up.
- If Gateway Board is inside enclosure, use tip of a paper clip to press and hold SW1 when connecting USB power supply to boot up.

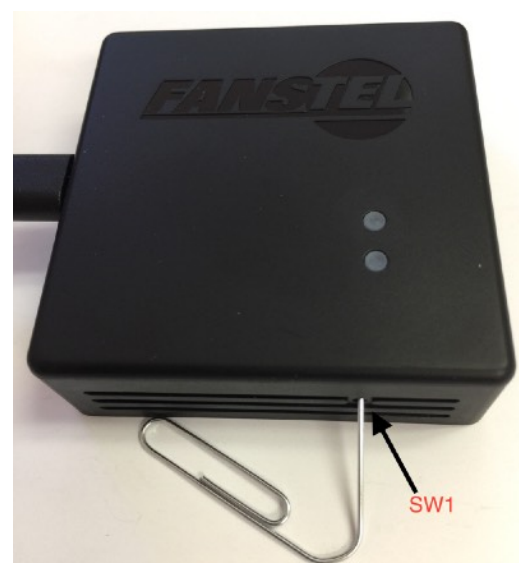
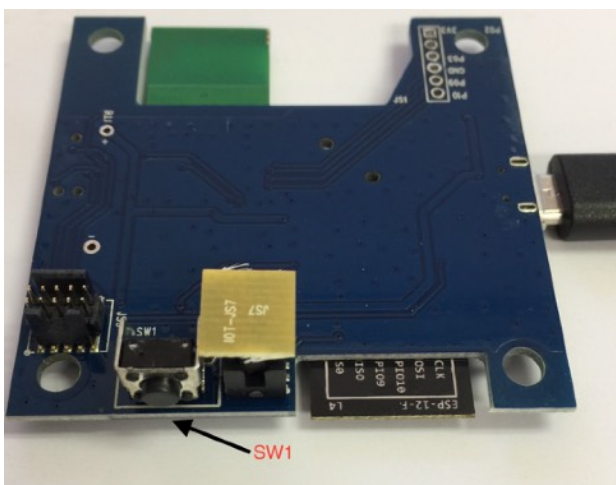

12. Use a smartphone to connect to WiFi AP

FanstelGW_XXXXXX

The XXXXXX is the device ID, 7A561D in the example.

Please remember this ID.

13. Open the web browser then go to 192.168.4.1

Enter your router information at the web page.

14. The Nordic and ESP chip's LED will flash when power

up. The baudrate is set to 115200 to check the log.

You should see the detail from log.



```

esp_mgos_init2      Mqtt_Demo 1.0 (20180321-071019/???)<LF>
esp_mgos_init2      Mongoose OS 2018032107 (20180321-071018/???)<LF>
esp_mgos_init2      CPU: ESP8266EX, 160 MHz, RAM: 52000 total, 46896 free<LF>
esp_mgos_init2      SDK 2.2.0-dev(e6d3ebb); flash: 4M<LF>
esp_print_reset_info Reset cause: 0 (power on)<LF>
mgos_vfs_dev_open   sysflash () -> 0x3fff08f4<LF>
mgos_vfs_mount      Mount SPIFFS @ / (dev 0x3fff08f4, opts {"addr": 32768, "size": 262144}
<LF>
mgos_vfs_mount      /: size 233681, used: 149345, free: 84336<LF>
mgos_sys_config_init MAC: 2E3AE818173F<LF>
mgos_sys_config_init WDT: 30 seconds<LF>
mgos_mdns_init      Listening on udp://:5353<LF>
mgos_mdns_hal_join_g Joining multicast group 224.0.0.251<LF>
bcn 0<LF>
del if1<LF>
del if0<LF>
us1<LF>
mode : null<LF>
mgos_wifi_setup     WiFi mode: off<LF>
mgos_http_server_ini HTTP server started on [80]<LF>
mgos_ota_shadow_init OTA over shadow initialised<LF>
mgos_ota_http_client Init done, ota_lib=(null), ota handler 1<LF>
mg_rpc_channel_mqtt 0x3fff022c esp8266_18173F/rpc/#<LF>
mg_rpc_channel_uart 0x3fff1524 UART0<LF>
mgos_init           Init done, RAM: 52000 total, 42156 free, 40016 min free<LF>
mgos_aws_shadow_init MQTT is not configured for AWS, not initialising shadow<LF>
mongoose_poll       New heap free LWM: 28184<LF>

```

15. Install the Android APP and input the ID.

16. Now the connection is made between the gateway and phone.

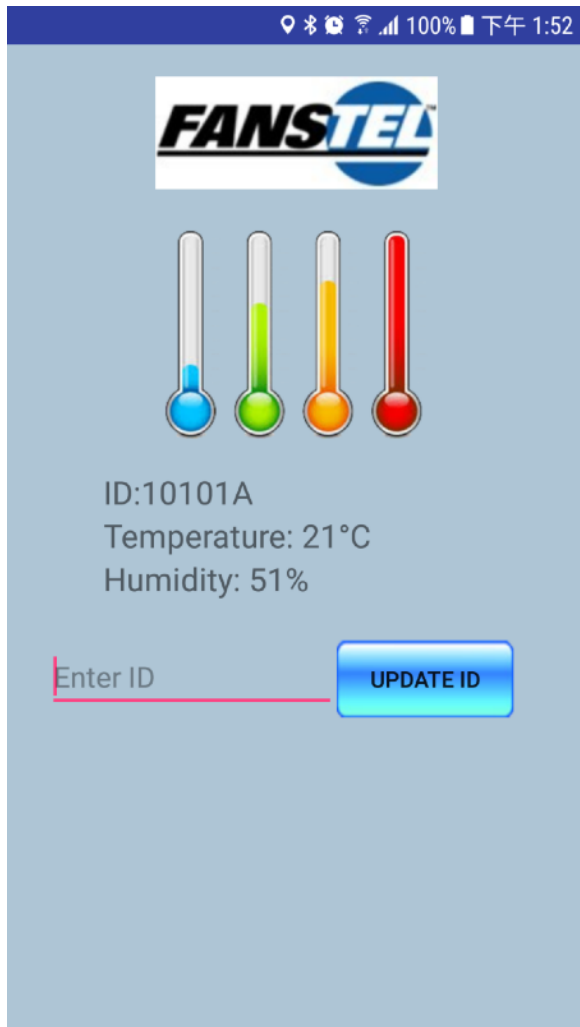

Connecting to Fanstel Mosquitto Server

Fanstel server is a Mosquitto free MQTT server.

MOS_MQTT_Auto publishes messages to MQTT broker in Fanstel server. These messages contains preset (artificial) sensor data. A Bluetooth sensor is not required to generate these sensor data.

MOS_MQTT_SensorTDK publishes messages to MQTT broker in Fanstel server. These messages contains real sensor data. A Fanstel or other BLE sensor box is required.

The Android APP subscribes to the same topic. Sensor data can be displayed on an Android device.

You might want to build your own MQTT server. The followings are basic Mosquitto set up information.

To install:

1. Download Win32OpenSSL V1.02
<http://slproweb.com/products/Win32OpenSSL.html>
Select bin when install. After install, copy libeay32.dll and ssleay32.dll to mosquito install folder.
2. Download pthreadVC2.dll and copy the file to mosquito install folder.
<ftp://sources.redhat.com/pub/pthreads-win32/dll-latest/dll/x86/>
3. Download mosquito native build version
mosquito-1.4.14-install-win32.exe (~200 kB) (Native build, Windows Vista and up, built with Visual Studio Community 2015)

Running mosquito.exe. The server started run as broker.

Please also make sure your fire wall is setup to pass the port 1883.

Open two DOS windows, one runs as Subscriber another one runs as Publisher

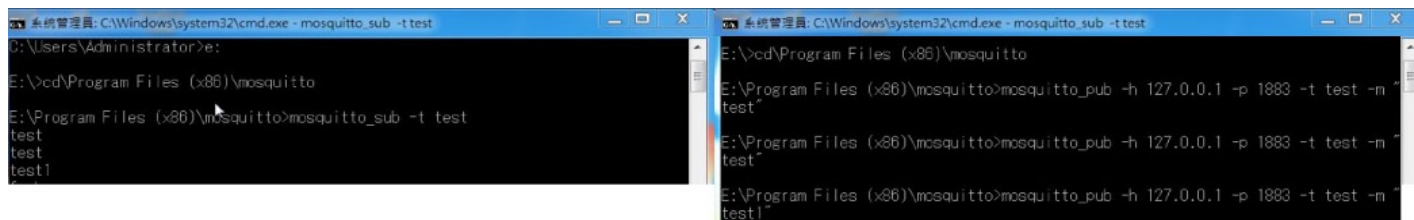

```
System Administrator: C:\Windows\system32\cmd.exe - mosquito_sub -t test
C:\Users\Administrator>
E:\>cd\Program Files (x86)\mosquito
E:\Program Files (x86)\mosquito>mosquito_sub -t test
test
test
test1

System Administrator: C:\Windows\system32\cmd.exe - mosquito_sub -t test
E:\>cd\Program Files (x86)\mosquito
E:\Program Files (x86)\mosquito>mosquito_pub -h 127.0.0.1 -p 1883 -t test -m "test"
E:\Program Files (x86)\mosquito>mosquito_pub -h 127.0.0.1 -p 1883 -t test -m "test"
E:\Program Files (x86)\mosquito>mosquito_pub -h 127.0.0.1 -p 1883 -t test -m "test1"
```

Publisher: `mosquito_pub -h YOUR ADDRESS -p 1883 -t YOUR TOPIC -m "YOUR MESSAGE"`

Subscriber: `mosquito_sub -h YOUR ADDRESS -t YOUR TOPIC`

Connecting to Google Cloud Platform IoT Core

Use the following procedures to connect gateway to Google Cloud Platform (GCP).

GCP Server setting:

Install the gcloud.

Install beta components:

`gcloud components install beta`

Authenticate with Google Cloud:

`gcloud auth login`

Create cloud project – choose your unique project name:

`gcloud projects create YOUR_PROJECT_NAME`

```
# Add permissions for IoT Core
gcloud projects add-iam-policy-binding YOUR_PROJECT_NAME --member=serviceAccount:cloud-iot@system.gserviceaccount.com --role=roles/pubsub.publisher
```

```
# Create PubSub topic for device data:
gcloud beta pubsub topics create telemetry-topic
```

```
# Create PubSub subscription for device data:
gcloud beta pubsub subscriptions create --topic telemetry-topic telemetry-subscription
```

```
# Create device registry:
gcloud beta iot registries create weather-station-registry --region us-central1 --event-pubsub-topic=telemetry-topic
```

Gateway side setting:

```
# Get project ID of your new project:
gcloud projects list
```

```
mos gcp-iot-setup --gcp-project YOUR_PROJECT_NAME --gcp-region us-central1 --gcp-registry YOUR_REGISTRY
```

```
mos gcp-iot-setup --gcp-project YOUR_PROJECT_ID --gcp-region europe-west1 --gcp-registry iot-registry
mos gcp-iot-setup --gcp-project fansteliot180409 --gcp-region us-central1 --gcp-registry weather-station-registry
```

Android APP setting:

```
#APP build.gradle
// ADD THIS AT THE BOTTOM
apply plugin: 'com.google.gms.google-services'
```

```
dependencies {
    .....
    compile 'com.google.firebase:firebase-core:12.0.1'
    compile 'com.google.firebase:firebase-database:12.0.1'
}
```

```
#Project build.gradle
dependencies {
    .....
    classpath 'com.google.gms:google-services:3.2.0'
}
allprojects {
    repositories {
        // ...
    }
}
```

BWG832FX, BWG840F/X Bluetooth 5 to WiFi Gateway

```
maven {  
    url "https://maven.google.com" // Google's Maven repository  
}  
}
```

#download google.json file copy to app/ folder
need to setup the project path.

MOS basic command

mos flash -port COM5 =>programming the firmware
mos -port COM5 =>Open the GUI via Serial Port
mos -port ws://192.168.0.188/rpc =>Open the GUI via web
mos wifi SSID PWD =>Setup WiFi
mos config-get => Get on board config file.

Programming WiFi Module in Production Gateway

The USB cable assembly included in the Development Kit can be used to load firmware into WiFi module of production gateway.

For high volume production, WiFi firmware can be preloaded in factory.

BWG832FX, BWG840F/X Bluetooth 5 to WiFi Gateway

4. Develop Codes for Bluetooth Modules

BWG832F Series gateway has a Nordic nRF52832 module. You need a Nordic nRF52DK (PCA10040) for programming.

- BWG832F with BT832F, Nordic nRF52832 with an integrated antenna.
- BWG832X with BT832X, Nordic nRF52832, SKYWORKS SKY66112, and an integrated antenna.
- BWG832XE with BT832XE, Nordic nRF52832, SKYWORKS SKY66112, and an u.FL connector for an external antenna.

Nordic Development Environment

Nordic Semiconductor provides a complete range of hardware and software development tools for the nRF52 Series devices. nRF52 DK board is recommended for firmware development. Document and Software development tools can be downloaded by the following links.

Get start with Nordic chip and all online documents.

http://infocenter.nordicsemi.com/index.jsp?topic=/com.nordic.infocenter.nrf52/dita/nrf52/development/nrf52_dev_kit.html&cp=1_1

Nordic SDK with many example projects.

https://developer.nordicsemi.com/nRF5_SDK/

Nordic development zone. You can search or ask a question there.

<https://devzone.nordicsemi.com/tutorials/b/getting-started/posts/development-with-gcc-and-eclipse>

Programming the Nordic chip

Download and install Nrf5x-Command-Line Tools

<https://www.nordicsemi.com/eng/nordic/Products/nRF52840/nRF5x-Command-Line-Tools-Win32/58850>

Download and install nRF Connect.

<https://www.nordicsemi.com/Software-and-Tools/Development-Tools/nRF-Connect-for-desktop>

Download and install Segger Embedded Studio.

<https://www.nordicsemi.com/Software-and-Tools/Development-Tools/Segger-Embedded-Studio>

Fanstel Sensors

Fanstel sensors are available with AMS ENS210 temperature and humidity sensors.

- SE832AF-210 with BLE module BT832AF.
- SE840F-210 with BLE module BT840F
- SE840X-210 with BLE module BT840X.

These sensors can be used in development and deployment. Additional sensors will be released later.

BWG832FX, BWG840F/X Bluetooth 5 to WiFi Gateway

Interfacing with a Fanstel Evaluation Board

If you have a Fanstel nRF52 module evaluation board.

- Connect Nordic nRF52DK debug out to Fanstel EV debug in as below.
- Connect Nordic DK to PC.
- Connect a DC power source to micro or mini USB port of Fanstel board.

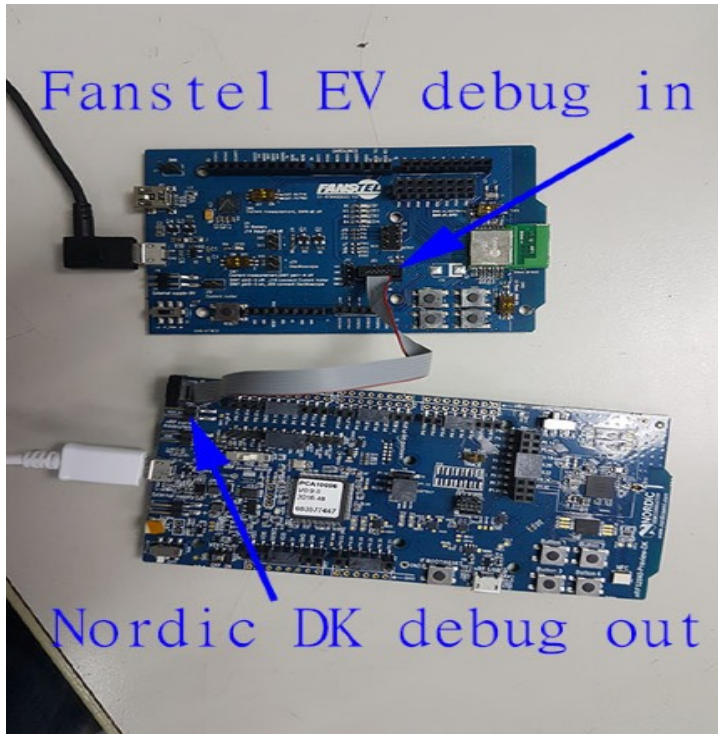

Check COM Port Connection

After connecting nRF52DK and an nRF52 sensor/evaluation board, you can see You can J-Link device and COM port on the PC control panel Device Manager.

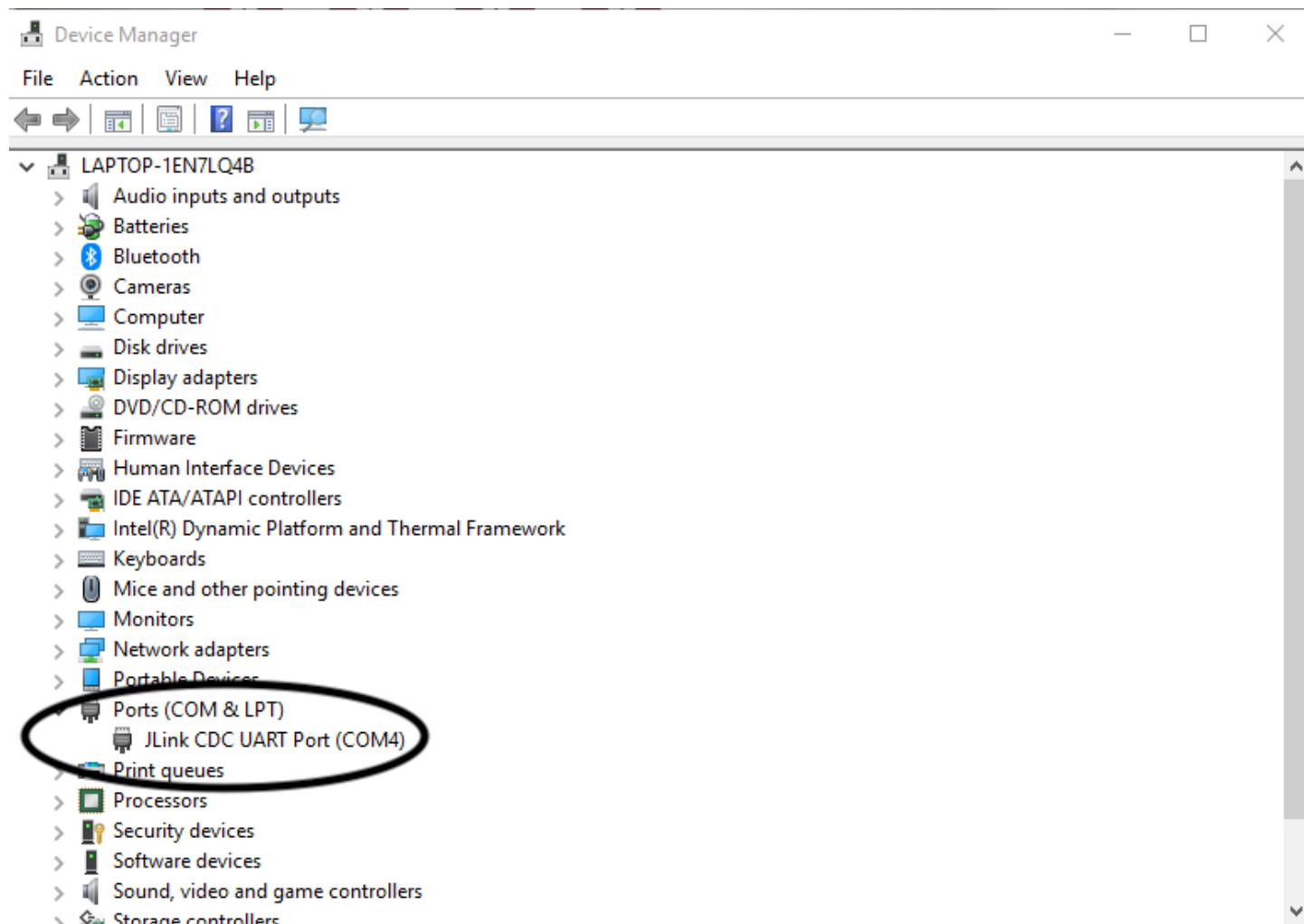

Starting Nordic nRF Connect

1. Open nRF Connect
2. Paunch Programmer
3. Select Device, PCA10056 for nRF52840DK
4. Add HEX files, SoftDevice and application codes
5. Click Erase and Write to begin programming

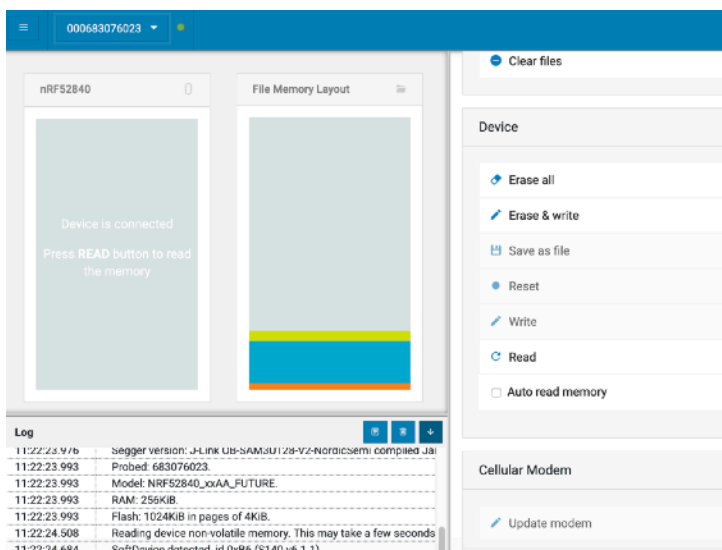
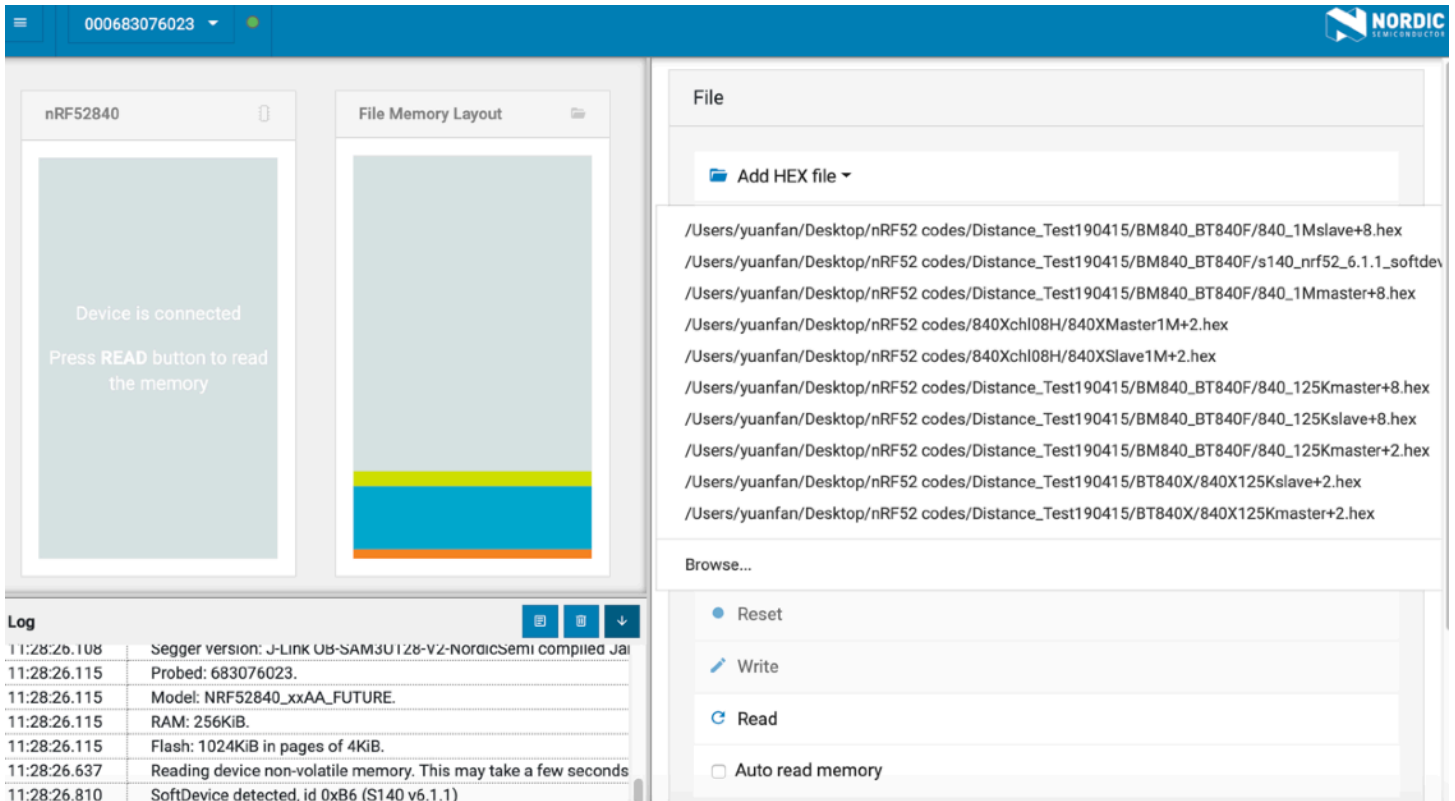

Over-The-Air DFU

The nRF52 SoC is supported by an Over-The-Air Device Firmware Upgrade (OTA DFU) feature. This allows for in the field updates of application software and SoftDevice.

Control Skyworks Power Amplifier in BT832X/XE

BWG832X and BWG832XE use SKYWORKS SKY66112-11 power amplifier. The connection diagram with nRF52832 control signal pins is below.

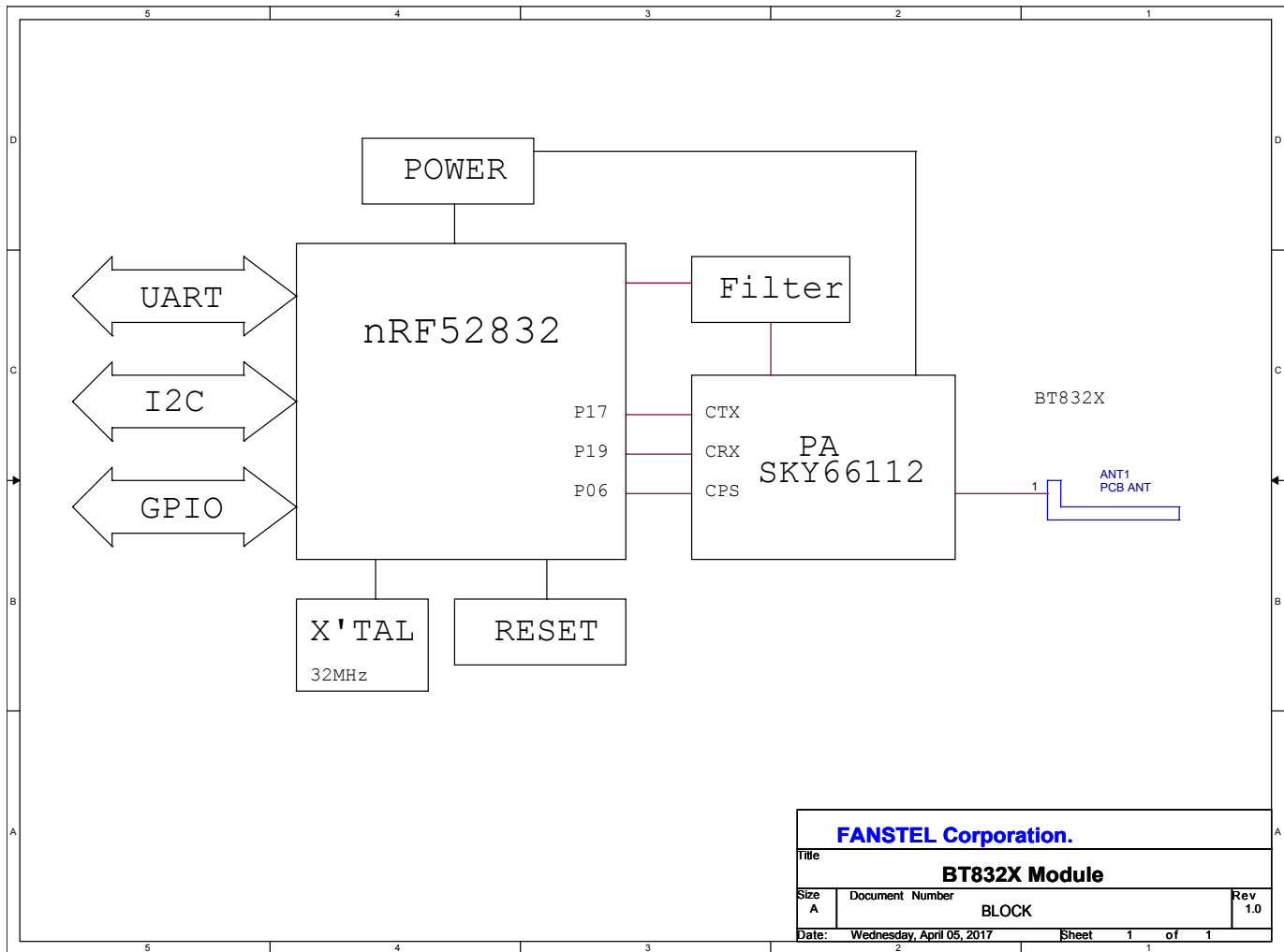

A firmware configuration example to control Skyworks SKY66112 power amplifier is below. This firmware file, SKY66112_PAconfig.txt can be downloaded from <http://www.fanstel.com/download-document/>.

```
//main.c
//config the PA/LNA
#ifdef APP_PA_LAN
#define APP_PA_PIN          17
#define APP_LNA_PIN        19
```



```
#define APP_CPS_PIN                6

#define APP_AMP_PPI_CH_ID_SET  0
#define APP_AMP_PPI_CH_ID_CLR  1
#define APP_AMP_GPIOTE_CH_ID  0

static void pa_Ina_setup(void)
{
    uint32_t err_code;
    nrf_gpio_cfg_output(APP_CPS_PIN);
        nrf_gpio_pin_clear(APP_CPS_PIN); //enable
        nrf_gpio_cfg_output(APP_PA_PIN);
        nrf_gpio_pin_clear(APP_PA_PIN); //
        nrf_gpio_cfg_output(APP_LNA_PIN);
        nrf_gpio_pin_clear(APP_LNA_PIN); //

static ble_opt_t pa_Ina_opts = {
    .common_opt = {
        .pa_Ina = {

            .pa_cfg = {
                .enable = 1,
                .active_high = 1,
                .gpio_pin = APP_PA_PIN
            },

            .Ina_cfg = {
                .enable = 1,
```

```

        .active_high = 1,
        .gpio_pin = APP_LNA_PIN
    },

    .ppi_ch_id_set = APP_AMP_PPI_CH_ID_SET,
    .ppi_ch_id_clr = APP_AMP_PPI_CH_ID_CLR,
    .gpiote_ch_id = APP_AMP_GPIOTE_CH_ID
}
}
};

NRF_GPIO->DIRSET |= (1 << APP_PA_PIN) | (1 << APP_LNA_PIN);
err_code = sd_ble_opt_set(BLE_COMMON_OPT_PA_LNA, &pa_lna_opts);
APP_ERROR_CHECK(err_code);

}
#endif

```

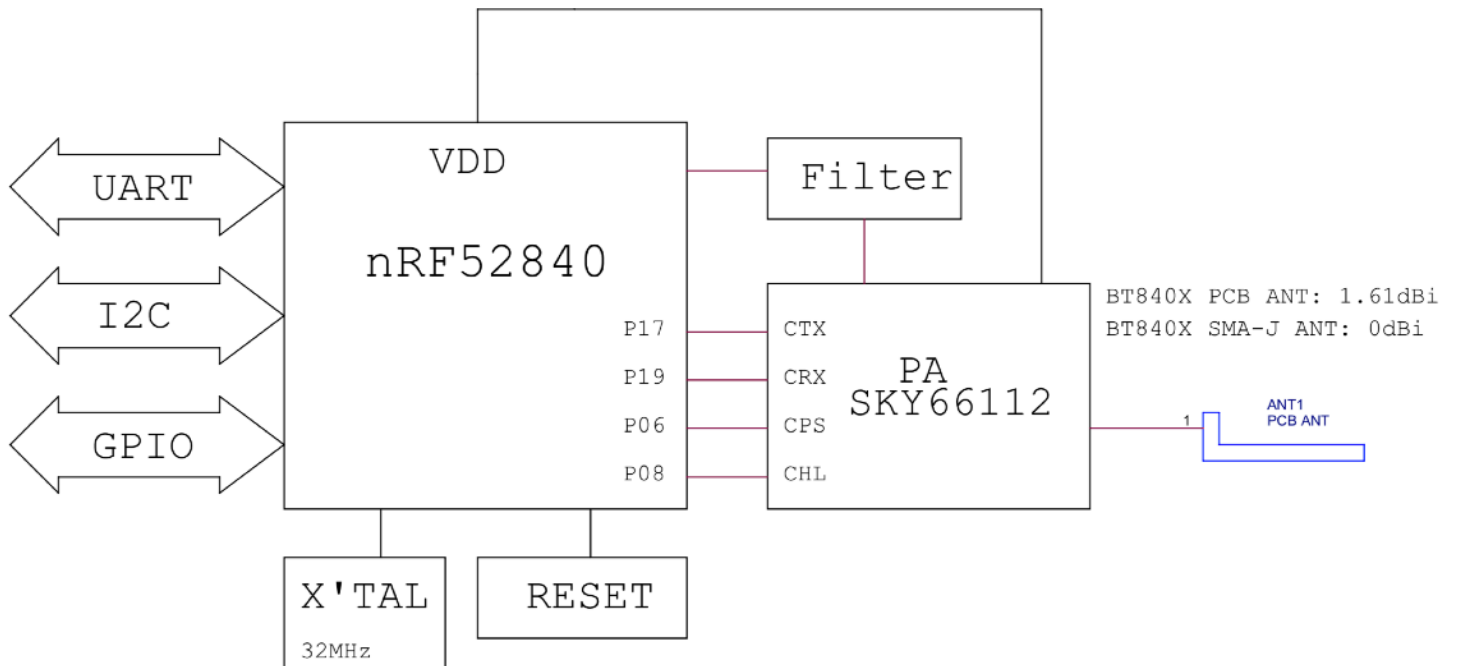

Control Skyworks Power Amplifier in BT840X/XE

BT840X uses SKYWORKS SKY66112-11 power amplifier. The connection diagram with control signal pins is below.

A firmware example to control Skyworks SKY66112 power amplifier is below. This firmware file can be downloaded from <http://www.fanstel.com/download-document/>.

You can set nRF52840 TX to up to + 8 dBm. The conditions for passing FCC and ISED certification testings:

- BT840X: Set nRF52840 TX to +2 dBm.
- BT840XE: Set nRF52840 TX to +2 dB and use Fanstel antenna ANT000.

The condition for passing CE and RCM certification testings:

- BT840X: Set nRF52840 TX to -4 dBm.
- BT840XE: Set nRF52840 TX to -4 dBm and use Fanstel antenna ANY000.

Header files

```
#ifndef PA_LNA_H__  
#define PA_LNA_H__
```

```
#include "ble.h"  
#include "app_error.h"  
#include "nrf_drv_gpiote.h"  
#include "nrf_drv_ppi.h"
```

```
void pa_lna_init(uint32_t gpio_pa_pin, uint32_t gpio_lna_pin);
```

```
#endif
```

Main program.

```
#include "pa_lna.h"
```

```
#define APP_PA_LAN
```

```
#ifdef APP_PA_LAN
```

```
#define APP_PA_PIN 17
```

```
#define APP_LNA_PIN 19
```

```
#define APP_CHL_PIN8
```

```
#define APP_CPS_PIN 6
```

```
int main(void)
```

```
{  
....  
#ifdef APP_PA_LAN  
    nrf_gpio_cfg_output(APP_CPS_PIN);  
    nrf_gpio_cfg_output(APP_CHL_PIN);  
    nrf_gpio_pin_set(APP_CHL_PIN);  
    nrf_gpio_pin_clear(APP_CPS_PIN); //enable  
    pa_lna_init(APP_PA_PIN,APP_LNA_PIN);  
#endif  
....  
}
```

SKY66112 control codes.

```
#include <stdint.h>  
#include <string.h>  
  
#include "pa_lna.h"  
#include "ble.h"  
#include "app_error.h"  
#include "nrf_drv_gpiote.h"  
#include "nrf_drv_ppi.h"  
  
void pa_lna_init(uint32_t gpio_pa_pin, uint32_t gpio_lna_pin)  
{  
    ble_opt_t opt;  
    uint32_t gpiote_ch = NULL;  
    ret_code_t err_code;  
  
    memset(&opt, 0, sizeof(ble_opt_t));  
  
    err_code = nrf_drv_gpiote_init();  
    if(err_code != NRF_ERROR_INVALID_STATE)  
        APP_ERROR_CHECK(err_code);  
  
    err_code = nrf_drv_ppi_init();  
    //if(err_code != MODULE_ALREADY_INITIALIZED)  
        APP_ERROR_CHECK(err_code);  
  
    nrf_ppi_channel_t ppi_set_ch;  
    nrf_ppi_channel_t ppi_clr_ch;  
  
    err_code = nrf_drv_ppi_channel_alloc(&ppi_set_ch);  
    APP_ERROR_CHECK(err_code);
```

```
err_code = nrf_drv_ppi_channel_alloc(&ppi_clr_ch);
APP_ERROR_CHECK(err_code);

nrf_drv_gpiote_out_config_t config = GPIOTE_CONFIG_OUT_TASK_TOGGLE(false);

if((gpio_pa_pin == NULL) && (gpio_lna_pin == NULL))
{
    err_code = NRF_ERROR_INVALID_PARAM;
    APP_ERROR_CHECK(err_code);
}

if(gpio_pa_pin != NULL)
{
    if(gpiote_ch == NULL)
    {
        err_code = nrf_drv_gpiote_out_init(gpio_pa_pin, &config);
        APP_ERROR_CHECK(err_code);

        gpiote_ch = nrf_drv_gpiote_out_task_addr_get(gpio_pa_pin);
    }

    // PA config
    opt.common_opt.pa_lna.pa_cfg.active_high = 1; // Set the pin to be active high
    opt.common_opt.pa_lna.pa_cfg.enable     = 1; // Enable toggling
    opt.common_opt.pa_lna.pa_cfg.gpio_pin   = gpio_pa_pin; // The GPIO pin to toggle tx
}

if(gpio_lna_pin != NULL)
{
    if(gpiote_ch == NULL)
    {
        err_code = nrf_drv_gpiote_out_init(gpio_lna_pin, &config);
        APP_ERROR_CHECK(err_code);

        gpiote_ch = nrf_drv_gpiote_out_task_addr_get(gpio_lna_pin);
    }

    // LNA config
    opt.common_opt.pa_lna.lna_cfg.active_high = 1; // Set the pin to be active high
    opt.common_opt.pa_lna.lna_cfg.enable     = 1; // Enable toggling
    opt.common_opt.pa_lna.lna_cfg.gpio_pin   = gpio_lna_pin; // The GPIO pin to toggle rx
}

// Common PA/LNA config
opt.common_opt.pa_lna.gpiote_ch_id = (gpiote_ch - NRF_GPIOTE_BASE) >> 2; // GPIOTE channel used for
radio pin toggling
opt.common_opt.pa_lna.ppi_ch_id_clr = ppi_clr_ch; // PPI channel used for radio pin clearing
opt.common_opt.pa_lna.ppi_ch_id_set = ppi_set_ch; // PPI channel used for radio pin setting

err_code = sd_ble_opt_set(BLE_COMMON_OPT_PA_LNA, &opt);
APP_ERROR_CHECK(err_code);
}
```

BWG832FX, BWG840F/X Bluetooth 5 to WiFi Gateway

Programming Bluetooth Module in Production Gateway

In production gateway (non-Development Kit), JS3 is not installed. The 10-pin flat cable included in DK can not be used to connect the **Debug out** of nRF52DK. A few options on programming Bluetooth module:

- Use a TAG connect cable **TC2050-IDC-NL-050-ALL** to connect **JS2** of gateway to nRF52DK **Debug out** to load bootloader and other firmware.
- If boot loader is loaded, SoftDevice and application firmware can be loaded using OTA.
- For high volume production, Bluetooth module codes can be preloaded at factory.

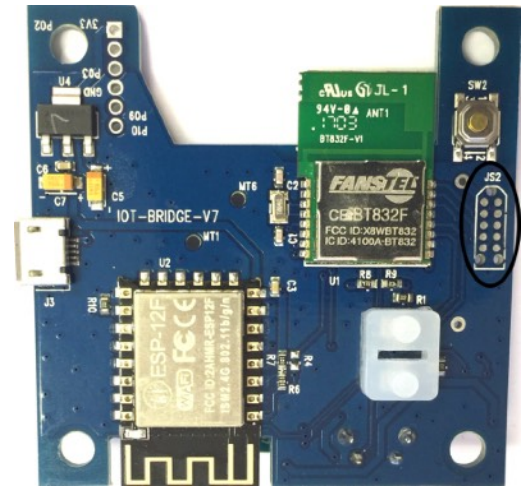

BWG832FX, BWG840F/X Bluetooth 5 to WiFi Gateway

5. Gateway Schematics

BWG832F/X Schematics

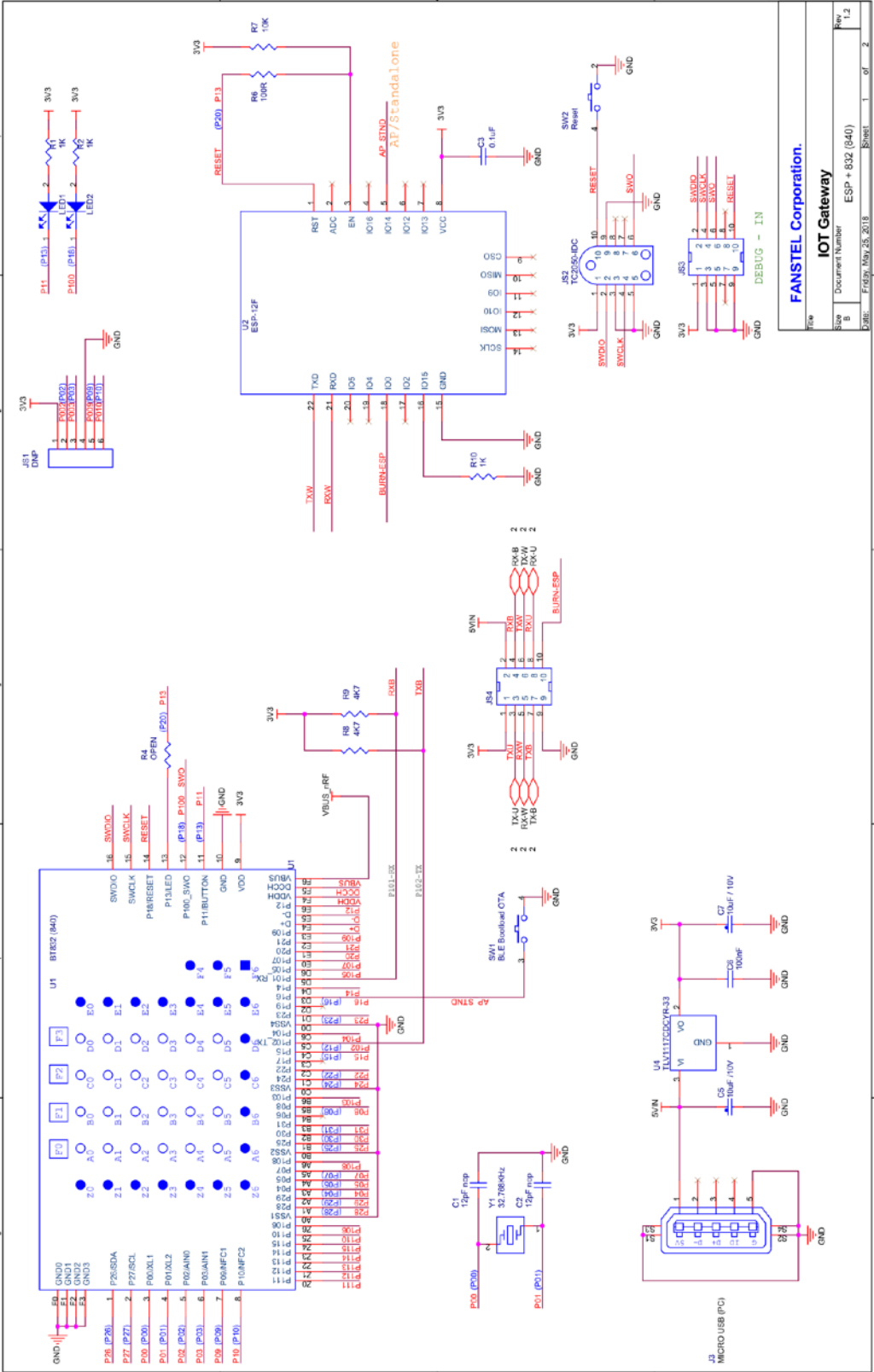

FANSTEL Corporation.	
Rev	IOT Gateway
Doc Number	ESP + 832 (840)
Rev	1.2
Sheet	1 of 2

BWG840F/X Schematics

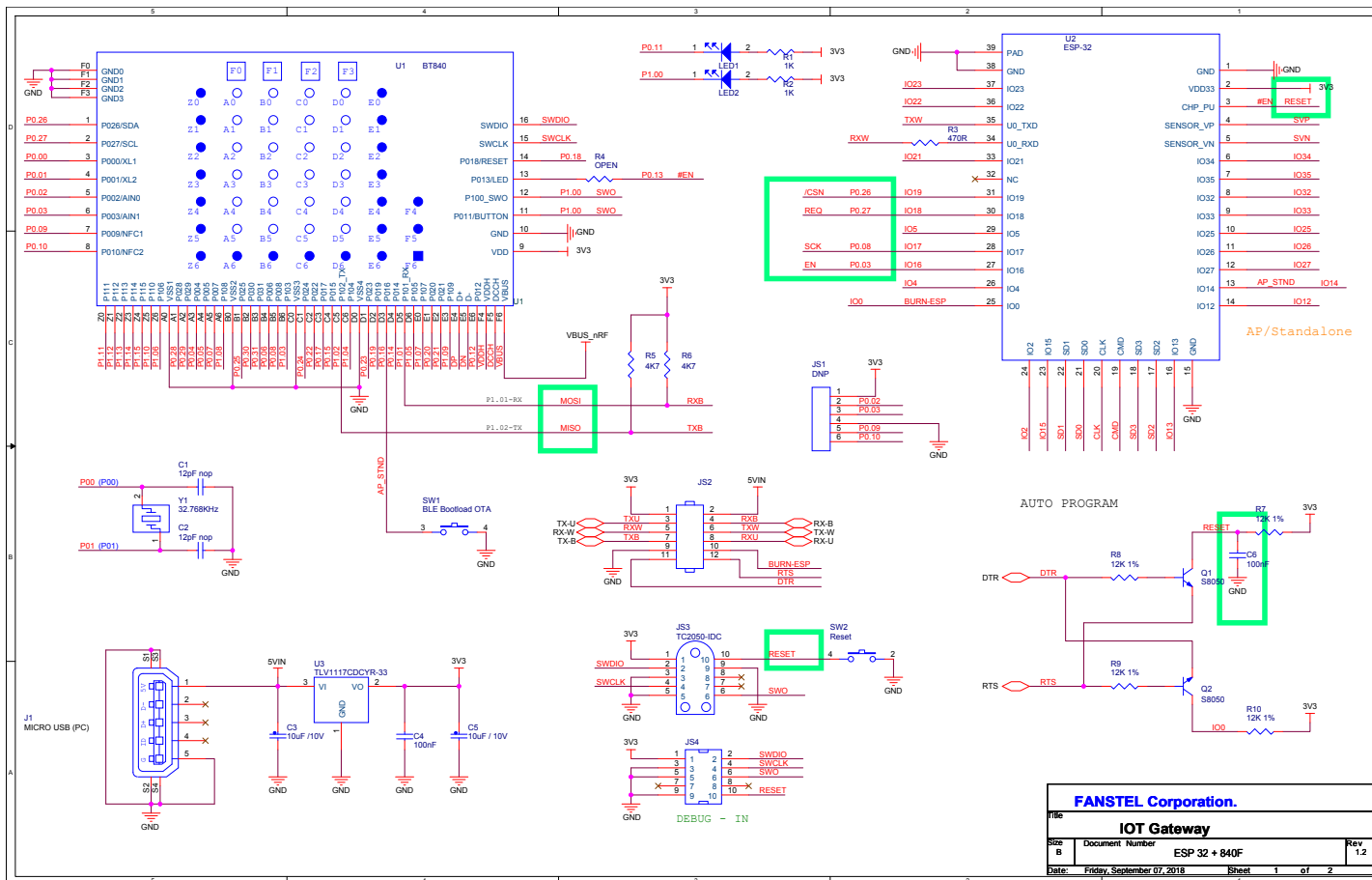

6. Wall Mounting

Wall mounting diagram is shown below. Self-tapping screws and expanded rubber are not included.

- Use wall mount bracket and a pencil to mark location of mounting holes on wall.
- Drill holes.
- Insert expanded rubbers into holes
- Use self-tapping screws to screw wall mount bracket on wall.
- Mount gateway or sensor on wall mount bracket.

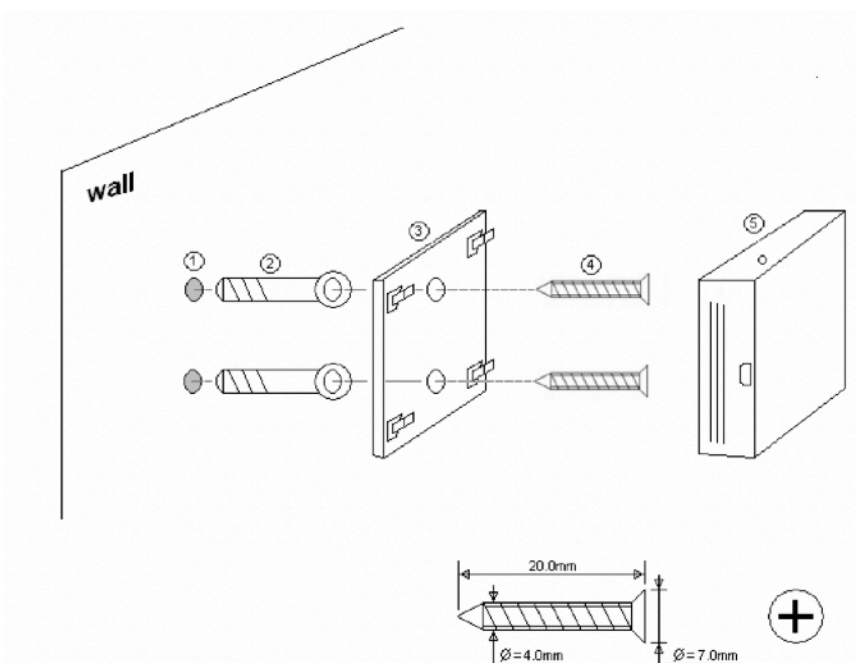

1	hole	$\varnothing = 6 \text{ mm}$, L = 30 mm
2	Expanded rubber	$\varnothing = 6 \text{ mm}$, L = 25 mm
3	Wall stand	
4	Self-tapping screws	$\varnothing = 4 \text{ mm}$, L = 20 mm
5	Sensor box	

BWG832FX, BWG840F/X Bluetooth 5 to WiFi Gateway

Revision History

- June 2018, Ver. 0.50: Initial draft copy release
- July 2018, Ver 0.60:, add FCC and IC certification numbers
- August 2019: Ver. 0.90, add BT840F Series gateways
- October 2019: Ver. 0.92, add wall mounting and BWG32.
- Nov. 2020: Ver. 1.00, update DK-BWG832F photo and certification status.
- Nov. 2021: Ver. 1.01, update stock items.

Contact Us

United States:

Fanstel Corp.

7466 E. Monte Cristo Ave. Scottsdale AZ 85260

Tel. 1 480-948-4928

Fax. 1-480-948-5459

Email: info@fanstel.com

Website: www.fanstel.com

Taiwan:

Fanstel Corp.

10F-10, 79 Xintai Wu Road

Xizhu, New Taipei City, Taiwan 22101

泛世公司

臺灣省新北市汐止區新臺五路79號10樓之10, 22101

Tel. 886-2-2698-9328

Fax. 886-2-2698-4813

Email: info@fanstel.com

Website: www.fanstel.com

China:

Fanstel Technologies Corp.

11 Jiale Street

Ping-Dih, Long-Gang, Shen Zhen, GD 518117

泛世康科技(深圳)有限公司

廣東省深圳市龍崗區坪地鎮佳樂街11號

Tel. 86-755-8409-0928

Fax. 86-755-8409-0973

QQ. 3076221086

Email: info@fanstel.com

Website: www.fanstel.com